

STR-0201 / STR-0301

Pislik Tutucu
Strainer



TEKNİK ÖZELLİKLER / TECHNICAL SPECIFICATIONS

| | |
|------------------------|-------------|
| Basınç Sınıfı | : PN16 |
| Gövde | : Pük döküm |
| Bağlantı Tipi | : Flanşlı |
| Pressure Rating | : PN16 |
| Body | : Cast Iron |
| Connection Type | : Flanged |

| Ürün / Product | Ölçü / Size |
|----------------|-------------|
| STR-0201X015 | DN15 |
| STR-0201X020 | DN20 |
| STR-0201X025 | DN25 |
| STR-0201X032 | DN32 |
| STR-0201X040 | DN40 |

SERTİFİKA / CERTIFICATE



GENEL ÖZELLİKLER / GENERAL PROPERTIES

Standart No / Standard No : TS 11494

Basınç Sınıfı / Pressure Rating : PN16

Maksimum Çalışma Sıcaklığı / Maximum Working Temperature : EPDM Conta ile (Standart) 110°C / With EPDM Gasket (Standard) 110°C
Klingerit Conta ile Pük Döküm +250°C - Sfero Döküm 300°C / With Klingerit Gasket Cast Iron +250°C - Ductile Iron +300°C

MALZEME / MATERIAL

Gövde / Body : Pük Döküm, Sfero Döküm / Cast Iron, Ductile Iron

Kapak / Bonnet : Pük Döküm, Sfero Döküm / Cast Iron, Ductile Iron

Filtre / Screen : Paslanmaz Çelik / Stainless Steel

Conta / Gasket : EPDM Standart (Opsiyonel Klingerit) / EPDM Standard (Optional Klingerit)

Civata / Bolt : Karbon Çelik / Carbon Steel

TEKNİK RESİM / TECHNICAL DRAWING

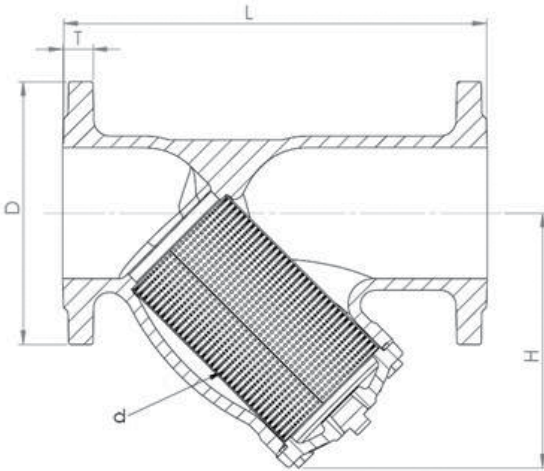

ÖLÇÜ TABLOSU / DIMENSIONS

| DN | L [mm] | H [mm] |
|----|--------|--------|
| 15 | 130 | 76 |
| 20 | 150 | 83 |
| 25 | 160 | 91 |
| 32 | 180 | 111 |
| 40 | 200 | 118 |