

> PİSLİK TUTUCU

STRAINER

STR-0201



CERTIFICATIONS



Basınç Sınıfı	: PN16
Gövde	: Pik döküm / Sfero döküm (DN 150- DN 300)
Filtre	: Paslanmaz çelik
Kapak	: Boşaltma tapalı
Conta	: EPDM
	Flanşlı

Pressure Rating	: PN16
Body	: Cast iron / Ductile iron
Screen	: Stainless steel
Cover	: With drain plug
Seat	: EPDM
	Flanged

PRODUCT	SIZE
STR-0201X050	DN 50
STR-0201X065	DN 65
STR-0201X080	DN 80
STR-0201X100	DN 100
STR-0201X125	DN 125
STR-0201X150	DN150
STR-0201X200	DN 200
STR-0201X250	DN 250
STR-0201X300	DN 300

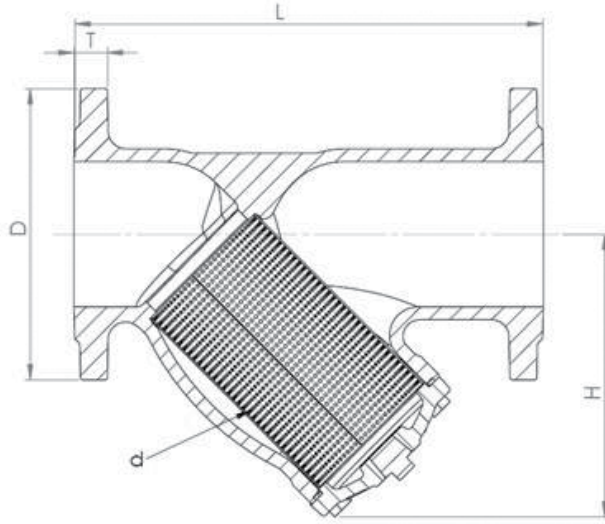

MALZEME / MATERIALS

Gövde / Body	: Pik döküm, Sfero döküm / Cast iron, Ductile iron
Kapak / Cover	: Pik döküm, Sfero döküm / Cast iron, Ductile iron
Filtre / Screen	: Paslanmaz çelik / Stainless steel
Boşaltma Tapası / Flag	: Sfero döküm / Ductile iron
Conta / Gasket	: EPDM
Civata / Bolt	: Karbon çelik / Carbon steel

GENEL ÖZELLİKLER / GENERAL PROPERTIES

Standart No	: TS 11494
Basınç Sınıfı / Pressure Rating	: PN16
Maksimum Çalışma Sıcaklığı / Maximum Working Temp.	: Pik döküm +250 °C / Cast iron +250 °C Sfero döküm +300 °C / Ductile iron +300 °C

DN	L	H	D	T	d	TAPA / PLUG
50	230	130	165	17	Ø 1,5	1,2"
65	290	156	185	17	Ø 1,5	1"
80	310	172	200	17	Ø 1,5	1"
100	350	215	220	17	Ø 3	1"
125	400	240	250	17	Ø 3	1 1/4"
150	480	282	285	17	Ø 3	1 1/2"
200	600	335	340	18	Ø 3	1 1/2"
250	730	460	400	20	Ø 3	2"
300	850	515	455	22,5	Ø 3	2"