

UDJ-0907

Limit Rotlu Dilatasyon Kompansatörü Dilatation Expansion Joints with Limit Rod



TEKNİK ÖZELLİKLER / TECHNICAL SPECIFICATIONS

Bağlantı Tipi	: Kaynaklı
Basıncı Sınıfı	: 16 bar / maks. 40 bar Opsiyonel
Sıcaklık	: 80 °C / 427 °C
Genişleme Miktarı	: 25 mm / 50 mm / 75 mm / 120mm
Connection Type	: Welded
Pressure Rating	: 16 bar / max. 40 bar Optional
Flange	: 80 °C / 427 °C
Expansion	: 25 mm / 50 mm / 75 mm / 120mm

Ürün / Product	Ölçü / Size
UDJ-0907X025	DN25
UDJ-0907X032	DN32
UDJ-0907X040	DN40
UDJ-0907X050	DN50
UDJ-0907X065	DN65
UDJ-0907X080	DN80
UDJ-0907X100	DN100
UDJ-0907X125	DN125
UDJ-0907X150	DN150
UDJ-0907X200	DN200
UDJ-0907X250	DN250
UDJ-0907X300	DN300

SERTİFİKA / CERTIFICATE



MALZEME / MATERIAL

Körük / Bellows	: Paslanmaz Çelik / Stainless Steel
Kaynak Boyun / Welded Neck	: Karbon Çelik / Carbon Steel
Tandem Boru / Intermediate Pipe	: Karbon Çelik / Carbon Steel
Bant / Band	: Paslanmaz Çelik / Stainless Steel
Kulak / Rod Holder	: Karbon Çelik / Carbon Steel
Ring / Ring	: Karbon Çelik / Carbon Steel
Somun / Nut	: Karbon Çelik / Carbon Steel
Saplama / Rod	: Karbon Çelik / Carbon Steel

TEKNİK RESİM / TECHNICAL DRAWING

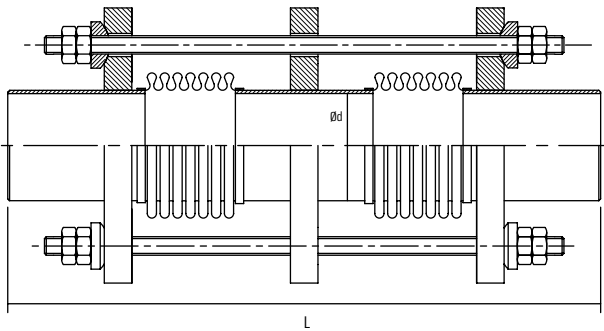

ÖLÇÜ TABLOSU / DIMENSIONS

DN	Inch	x [mm]	L [mm]				Ød	s	ØD	Körük Efektif Alanı Bellows Effective Area
			y ± 50mm	y ± 100mm	y ± 150mm	y ± 200mm				
25	1"	30	540	640	740	840	42,4	3,2	147	17,87
32	1 1/4"	30	540	640	740	840	42,4	3,2	147	17,87
40	1 1/2"	30	540	640	740	840	48,3	3,2	147	23,25
50	2"	30	610	710	810	910	60,3	3,6	161	37,02
65	2 1/2"	60	610	710	810	910	76,1	3,6	189	57,49
80	3"	60	660	760	860	960	88,9	4	211	78,47
100	4"	60	660	760	860	960	114,3	4,5	242	126,98
125	5"	60	700	900	1000	1100	139,7	5	282	185,91
150	6"	60	700	900	1000	1100	168,3	5	327	266,34
200	8"	60	750	950	1050	1150	219,1	6,3	419	441,34
250	10"	60	850	1050	1150	1250	273	6,3	491	678,87
300	12"	60	1000	1200	1300	1400	323,9	7,1	542	950,88