

# WAFER KELEBEK VANA

## BWN SERİSİ



### GENEL ÖZELLİKLER

Basınç Sınıfı	: PN16
Standart No	: TS EN593
Maksimum Çalışma Basıncı (Sürekli)	: 11 bar
Maksimum Çalışma Sıcaklığı	: EPDM için 120 °C (Su) NBR için 90 °C (Su ve madeni yağ)
Müsaade edilen fark basıncı (Sürekli)	: DN 40 - DN200 3 bar - DN250-DN300 1,5 bar
El kumandalı (DN40...DN200)	
Dişli kutulu (DN250...DN300)	

### MALZEME

Gövde	: BWN 0201 Pik döküm (GG25) BWN 0301 Sfero döküm (GGG40)
Klape	: Nikel kaplı sfero döküm / Paslanmaz çelik
Sit	: EPDM / NBR / Viton
Üst Mil	: Paslanmaz çelik
Alt Mil	: Paslanmaz çelik
Kol	: Alüminyum
Ayna	: Alüminyum
Cıvata	: Karbon çelik (kaplı)
Somun	: Karbon çelik (kaplı)

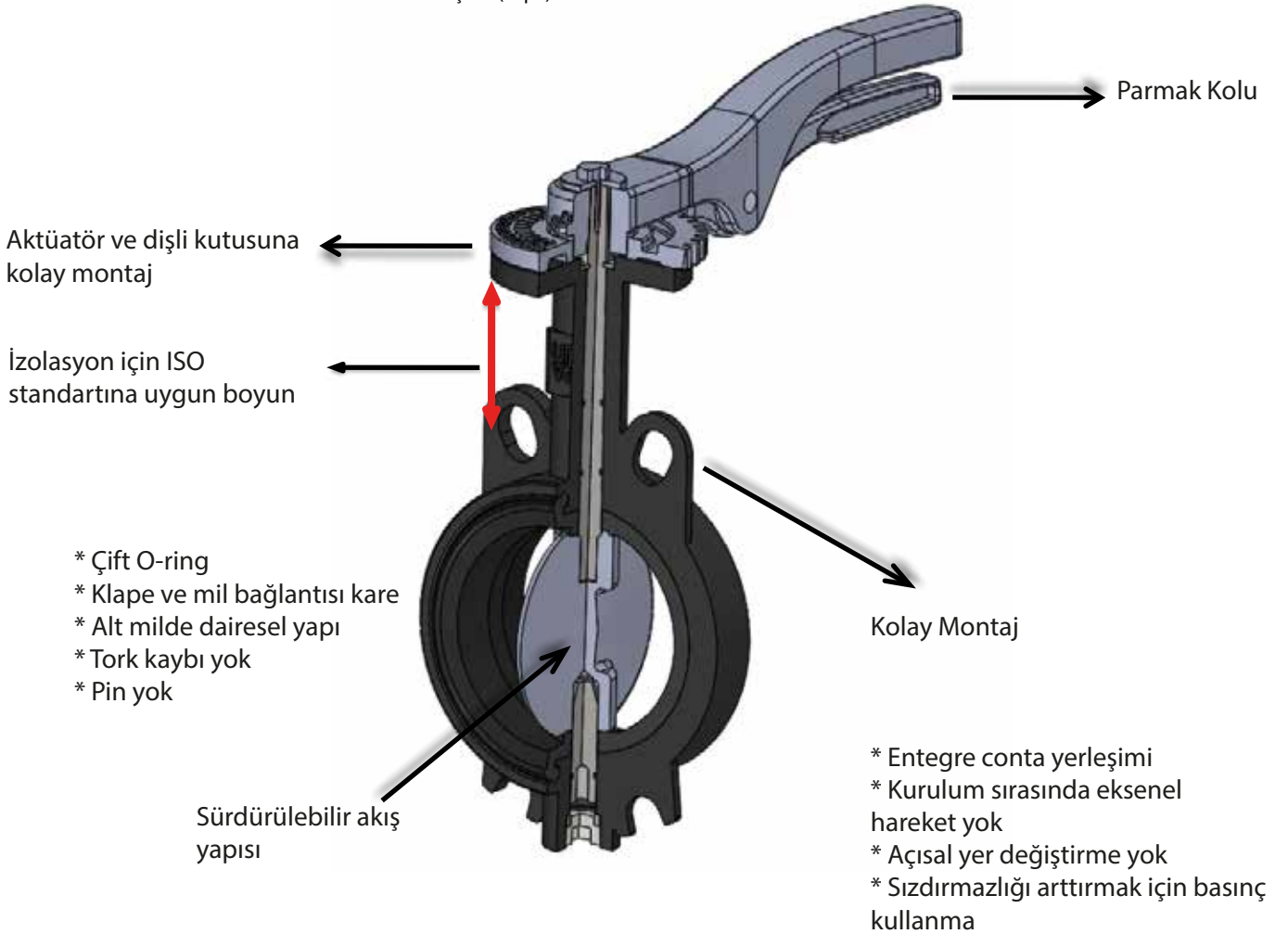

CERTIFICATIONS



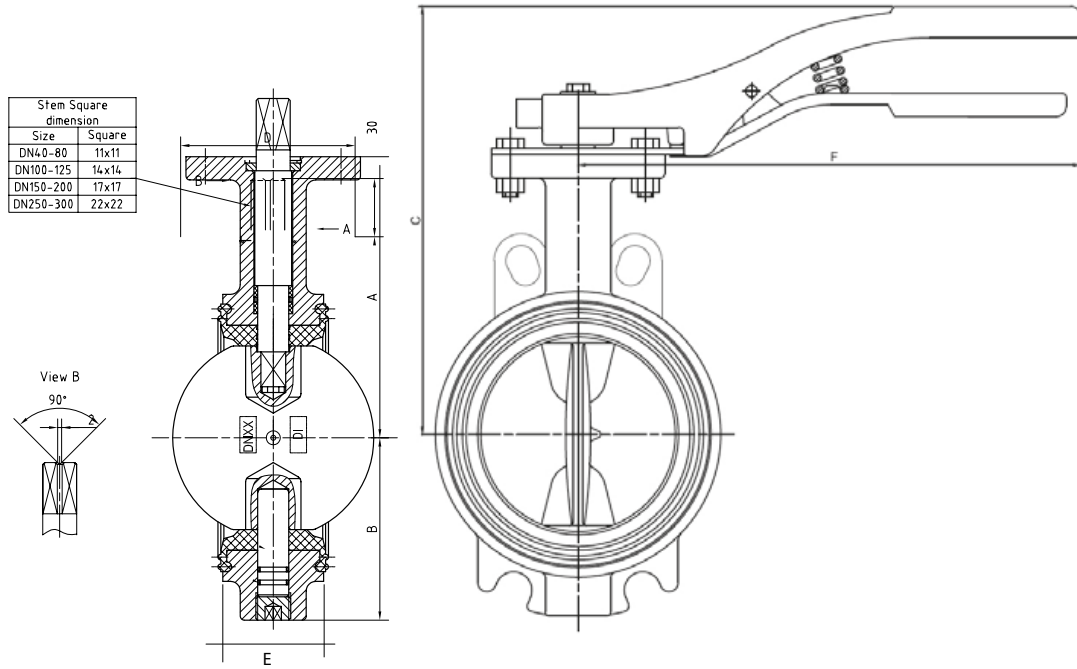

DN	A	B	E	D	F	C	Kv
40	140	63,5	34,5	90	260	217	49,5
50	140	68,5	43	90	260	217	115
65	152	76	45	90	260	229	255
80	160	85	46	90	260	237	375
100	180	100	51,5	90	260	257	760
125	191	120	56	90	260	268	1030
150	202	132	56,5	90	260	279	1790
200	237	160	60	125	326	336	3450
250	274	200	68,5	125	416	376	5050
300	312	230	79,5	125	416	414	7420

Kv values

